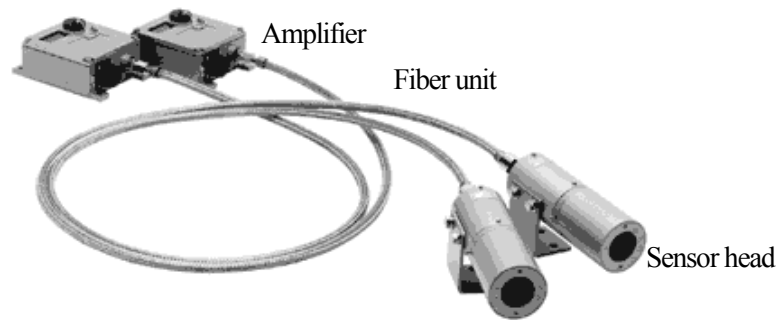

NEW PRODUCTS

HOKUYO**OPTICAL FIBER, LASER TYPE CMD****LAV-10 series**

This is a new optical fiber type CMD using semi-conductor laser as light source. This equipment is composed of transmitter(Sensor head, heat-resistance fiber and amplifier) and receiver and detects steel material which passes through between them. It emits more powerfully compared with LED type so that high performance with margin in bad environment is possible.

*This doesn't specify power source. It is capable of being used within the scope of 100 to 240VAC.

*Water-cooling or air-purge isn't required for sensor head because non-air dust purge hood is applied.

*8-point LED display unable to monitor the margin and emitting state.

*Warning output is provided.

Specifications

Model No.	Amplifier : Basic type LAV-10P/Strong power type LAV-11P(Projector), LAV-10A(Receiver) Sensor head : FHM-211-1, FHM-311 Fiber unit *1 : FHV-321(2m), FHV-351(5m), FHV-411(10m)
Safety standard	Class 1(JIS C6802)
Detectable object	Steel material with 100mm in dia. or more(FHM-311)
Detectable distance	50m(Detection margin : 10,000 times or more at 10m *2)
Power source	100 to 240VAC(+10%, - 15%, 50/60Hz)
Power consumption	Projector : 5VA or less, Receiver : 5.5VA or less
Control output	
Warning output	1C relay contact(250VAC 3A, 30VDC 5A, COS ϕ =1), Photo-coupler(120V or less, 100mA)
Light-emission amount	
Lowering output	
Analog voltage output	DC voltage output in proportion to light-reception amount(Saturated value 9V or more but do not use it except for adjustment)
Response time	Contact output : 40msec or less, Contactless output : 30msec or less
Operation mode	Changeover of DARK-ON/LIGHT-ON
Connection	Connector type(Cable 2m)
Fiber unit characteristics	Allowable bending radius : 100mm, Max. pressure : 784MPa, Tension strength : 490N
Ambient illuminance	Incandescent lamp : 10,000lux
Ambient temperature	Amplifier : -10 to +55 degrees C, Sensor head/Fiber unit : -10 to +200 degrees C
Ambient humidity	45 to 85%RH(Not frozen)
Insulation resistance	20M ohm or more(Between power/output contact and case by 1,000V megger)
Withstand voltage	1,500VAC/min. (Between power/output contact and case)
Vibration resistance	10 to 55Hz Double amplitude 1.5mm Each 2 hour in X, Y and Z directions
Impact resistance	490m/s ² Each 3 time in X, Y and Z directions
Protective structure	Amplifier : IP64(IEC standard) Sensor head : IP66(IEC standard) Fiber unit : Corrugated tube with blade(SUS)
Case	Amplifier : Aluminum die-casting, Sensor head : Aluminum
Weight	Amplifier : Approx. 950g Sensor head : FHM-211-1 approx. 1.5kg, FHM-311 approx. 4.0kg, Fiber unit : FHV-321 approx. 1.0kg, FHV-351 approx. 1.8kg, FHV-411 approx. 2.8kg

*1 3m, 15m and 20m type are also available.

*2 In case of using FHV-321 and FHM-211-1

Characteristics data

*LAV-10P/10A

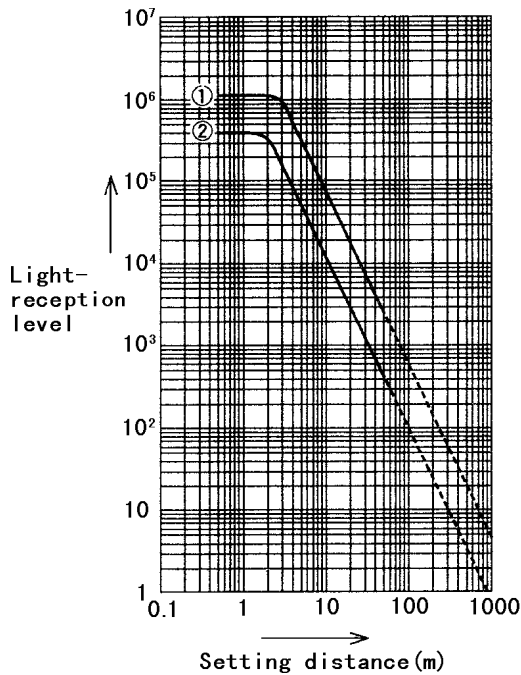

*LAV-11P/10A

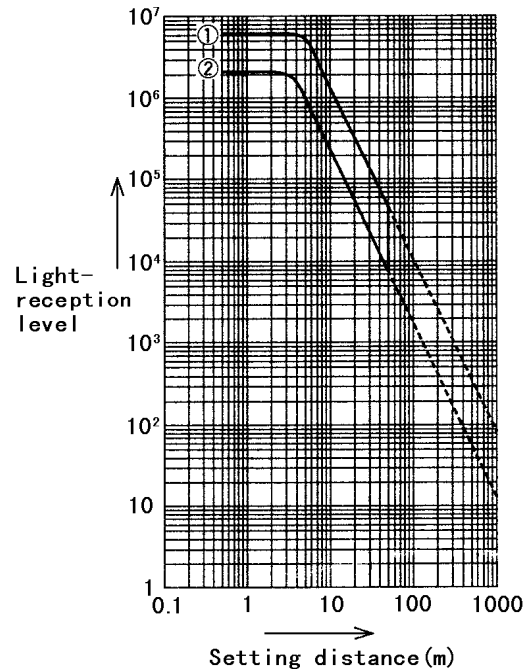

Note) Fiber length 5m(Both projector and receiver)
Fiber head ① FHM-311 ② FHM-211-1

External dimension

*Amplifier unit(Common for projector and receiver)

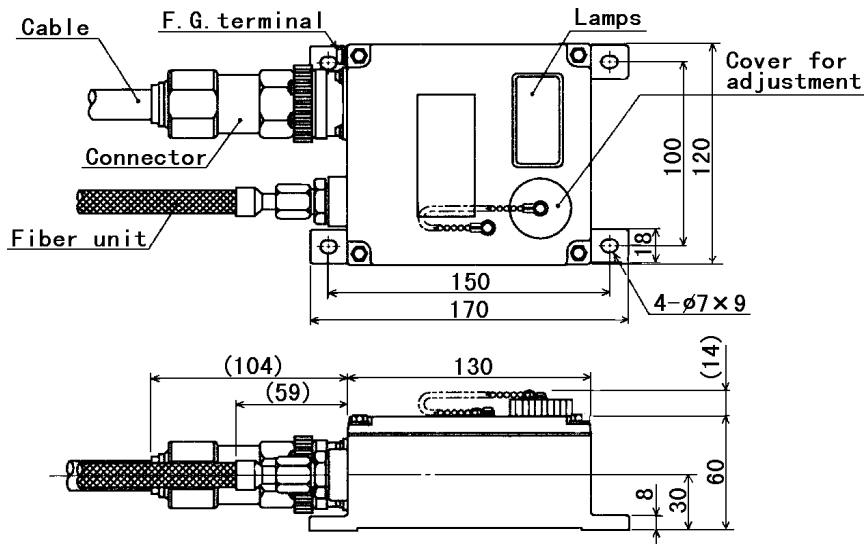

PHOTO SENSOR, LASER SENSOR, MICROWAVE SENSOR, COUNTER, AUTOMATIC DOOR



HOKUYO AUTOMATIC CO.,LTD.
2-1-12 Sonezaki,Kita-ku,Osaka,Japan
Tel(06)6362-6331 Fax(06)6365-8985
<http://www.hokuyo-aut.co.jp>
E-mail:foreign-trade@hokuyo-aut.co.jp